



Department of Safety and Professional Services
Division of Industry Services
Plumbing Product Review
4822 Madison Yards Way
P.O. Box 7162
Madison, Wisconsin 53707-7162
Phone 608-266-2112
Web <http://dsps.wi.gov>
Email dsps@wisconsin.gov
TTY: Contact Through Relay

Governor Tony Evers Dawn Crim, Secretary

May 31, 2022

Dept. of Safety and Professional Services
Bureau of Technical Services
Division of Industry Services
Brad Johnson - Section Chief
4822 Madison Yards Way
Madison WI 53705

Re: Description: POWTS Component Manual
Manufacturer: Dept. of Safety and Professional Services
Product Name: In-Ground Soil Absorption Component Manual for Private Onsite Wastewater Treatment Systems
Version 2.1 (May 2022-2027)
Model Number(s): v. 2.1
eSLA PTO No.: PP-051700077-PTOVPCR

The specifications and/or plans for this plumbing product have been reviewed and determined to comply with chapters SPS 382 through 384, Wisconsin Administrative Code, and Chapters 145 and 160, Wisconsin Statutes.

The Department hereby issues an approval based on the Wisconsin Statutes and the Wisconsin Administrative Code. This approval is valid until the end of May 2027.

This approval is contingent upon compliance with the following stipulation(s):

1. A copy of this approval letter shall be submitted with all plans using the In-Ground Soil Absorption Component Manual for Private Onsite Wastewater Treatment Systems Version 2.1 (May 2022-2027).

Plans submitted without a copy of this approval letter may be denied.
2. This approval recognizes that POWTS systems designed, installed and maintained in accordance with this manual will provide treatment and dispersal of domestic wastewater that is acceptable in the context of ch. 383 Wis. Adm. Code.
3. Systems installed in accordance with this POWTS Component Manual shall use wastewater tanks approved by the department. If a given tank is approved and meets the published specifications contained in the manual, then redundant approval of the tank is not required. The installation shall not compromise the structural integrity of the tank.
4. Systems installed in accordance with this POWTS Component Manual shall be installed, maintained and used in strict accordance with the manufacturer's published instructions, Chapters 381-386 Wis. Adm. Code and this product approval. If there is a conflict between the manufacturer's instructions and the Wis. Adm. Code or this Plumbing Product Approval, then the Wis. Adm. Code and this Plumbing Product Approval shall take precedence.
5. Complete operation and maintenance instructions POWTS systems designed in accordance with this manual shall be provided to each system owner and remain onsite.
6. Systems designed in accordance with this manual shall be installed by persons holding the proper license or registration in accordance with Wis. Stats. § 145.
7. Drain, waste and vent piping used to install these systems shall conform to s. SPS 384.30 (1), (2) and (3) Wis. Adm. Code.

8. Cleanouts shall be installed in drain piping associated with the installation of these systems in accordance with s. SPS 382.35 Wis. Adm. Code.
9. Commercial food processing, food production, food service, restaurants, taverns and similar establishments which may generate greases, fats, oils or similar substances; shall have state-approved grease interceptors installed upstream of POWTS systems designed in accordance with this manual in accordance with s. SPS 382.34 Wis. Adm. Code.
10. DSPS POWTS plan approval shall be obtained from the department's Private Sewage Section, or the appropriate agent county, for:
 - a. each installation of POWTS systems designed in accordance with this manual; and
 - b. high-strength and/or commercial POWTS systems designed in accordance with this manual.
11. A sanitary permit shall be obtained, in accordance with s. SPS 383.21 Wis. Adm. Code, from the county, or other local authority having jurisdiction, for each proposed installation of systems designed in accordance with this manual.
12. A complete and acceptable soil evaluation report, conforming to s. SPS 385.40 Wis. Adm. Code, shall be performed for all proposed systems designed in accordance with this manual.

Technical notations:

- a. This approval supersedes the approval issued May 9, 2017 under product file no. 20170147.

The department is in no way endorsing this component manual or any advertising and is not responsible for any situation which may result from its use.

Sincerely,

Brad Johnson – Section Chief
Department of Safety and Professional Services
Bureau of Technical Services
Division of Industry Services
Phone: 920 492-5605
Email: Bradley.Johnson@Wisconsin.gov

**IN-GROUND SOIL ABSORPTION COMPONENT MANUAL FOR
PRIVATE ONSITE WASTEWATER TREATMENT SYSTEMS**

**(VERSION 2.1)
May 2022
Exp. end of May 2027**

**State of Wisconsin
Department of Safety & Professional Services
Division of Industry Services**



**IN-GROUND SOIL ABSORPTION COMPONENT MANUAL FOR
PRIVATE ONSITE WASTEWATER TREATMENT SYSTEMS
(VERSION 2.1)**

TABLE OF CONTENTS

	Page
I. Introduction and Specifications	3
II. Definitions	9
III. Description and Principle of Operation	9
IV. Soil and Site Requirements	11
V. Cover Material	11
VI. Design	11
VII. Site Preparation and Construction	17
VIII. Operation, Maintenance and Performance Monitoring	19
IX. References	20
X. In-ground Worksheet	21
XI. Example Worksheet	24
XII. Plan submittal and Installation Inspection	27

**Published on May 2022 by Dept. of Safety & Professional Services
Division of Industry Services
Safety and Buildings Publication SPD-10705**

ADA Statement

The Department of Safety & Professional Services is an equal opportunity service provider and employer. If you need assistance to access services or need material in an alternate format, please contact the Department at (608) 266-2112 or TTY Contact Through Relay.

I. INTRODUCTION AND SPECIFICATIONS

This Private Onsite Wastewater Treatment System (POWTS) component manual provides design, construction, inspection, operation, and maintenance specifications for an in-ground soil absorption component. However, these items must accompany a properly prepared and reviewed plan acceptable to the governing unit to help provide a system that can be installed and function properly. Violations of this manual constitute a violation of chs. SPS 383 and 384, Wis. Adm. Code. The in-ground soil absorption component must receive influent flows and loads less than or equal to those specified in Table 1. When designed, installed and maintained in accordance with this manual, the in-ground soil absorption component provides treatment and dispersal of domestic wastewater in conformance with ch. SPS 383 of the Wis. Adm. Code. Final effluent characteristics will comply with s. SPS 383.41, Wis. Adm. Code when inputs are within the range specified in Tables 1 to 3. Design variations of this manual will constitute an “Individual Site Design” which require exclusive plan review conducted by state staff.

Note: Detailed plans and specifications must be developed and submitted to be reviewed and approved by the governing unit having authority over the plan for the installation. Also, a Sanitary Permit must be obtained from the department or governmental unit having jurisdiction. See Section XII for more details.

Table 1 INFLUENT FLOWS AND LOADS	
Design Wastewater flow (DWF)	≤ 5000 gal/day
Dosing of Effluent required when DWF	> 1500 gal/day
Monthly average value of Fats, Oil and Grease (FOG)	≤ 30 mg/L
Monthly average value of five day Biochemical Oxygen demand (BOD ₅)	≤ 220 mg/L
Monthly average value of Total Suspended Solids (TSS)	≤ 150 mg/L
Wastewater particle size	≤ 1/8 inch
Design wastewater flow (DWF) from one- or two-family dwellings	Based on s. SPS 383.43 (3), (4) or (5), Wis. Adm. Code
Design wastewater flow (DWF) from public facilities	≥ 150% of estimated wastewater flow in accordance with Table 4 of this manual or s. SPS 383.43 (6), Wis. Adm. Code
Volume of a single dose when a pressure distribution system is utilized to disperse effluent [(Use of pressure distribution is dictated by s. SPS 383.44(55)]	≥ 5 times the void volume of the distribution lateral(s) and ≤ 20% of the design wastewater flow
Volume of a single dose to soil absorption component when effluent is delivered to a non-pressure distribution system	≤ 20% of the design wastewater flow
Distribution cell area per orifice when pressurized distribution is used	≤ 12 ft ²

Table 2 SIZE AND ORIENTATION	
Minimum area of distribution cell	≥ Design wastewater flow ÷ soil application rate for the in situ soil at the infiltrative surface or a lower horizon if the lower horizon adversely affects the dispersal of wastewater in accordance with s. SPS 383.44 (4) (a) and (c), Wis. Adm. Code.
Distribution cell width	≥ 1 foot and ≤ 6 feet
Distribution cell depth	≥ 8 inches + nominal size of distribution pipe
Depth of cover over distribution cell	≥ 12 inches
Depth of cover over distribution cell measured from in situ soil surface	≥ 0 inches

Table 3 OTHER SPECIFICATIONS	
Slope of in situ soil	≤ 25% in area of component
Vertical separation between distribution cell and seasonal saturation defined by redoximorphic features, groundwater, or bedrock	≥ Equal to depth required by s. SPS 383 Table 383.44-3, Wis. Adm. Code
Bottom of distribution cell	Level
Horizontal separation between distribution cells	≥ 3 ft.
Distance between bottom of distribution lateral and in situ soil when stone aggregate is used	≥ 6 inches
Distance between top of distribution lateral and geotextile fabric when aggregate is used	≥ 2 inches
Distribution cell aggregate material	Meets requirements of s. SPS 384.30 (6) (i), Wis. Adm. Code for stone aggregate
Piping material in the distribution system	Meets requirements of s. SPS 384.30 (2), Wis. Adm. Code for its intended use
Piping material for observation, vent, and observation/vent pipes	Meets requirements of s. 384.30 Table 384.30-1, Wis. Adm. Code
Leaching chamber	Meets requirements of s. SPS 384.30 (6) (h), Wis. Adm. Code.
Geotextile fabric cover over distribution cell when stone aggregate is used	Geotextile fabric meeting s. SPS 384.30 (6) (g), Wis. Adm. Code
Slope of gravity flow perforated distribution lateral piping	≤ 4 inches per 100 feet away from distribution boxes, drop boxes or header

Table 3
OTHER SPECIFICATIONS
(continued)

Location of gravity flow perforated distribution pipe in distribution cell	Centered in the width of the cell or equally spaced in the width of the cell
Location of leaching chambers in distribution cell	Located as follows: 1. Single row of chambers that are in contact with the soil of the distribution cell walls, or 2. Multiple rows of chambers that are in contact with each other and have the outside sides in contact with the soil of the distribution cell walls
Length of distribution pipe for components using stone aggregate and gravity flow distribution	≥ Equal to length of distribution cell minus 6 feet
Distance between distribution pipe end orifice and end of distribution cell for components using stone aggregate and gravity flow distribution	≤ 3 feet
Length of leaching chamber row	Chambers extend to end walls of distribution cell
Number of observation pipes per distribution cell	≥ 2
Location of observation pipes	For flexibility in pipe location, see VII. C. 5.
Design and installation of observation pipes installed in stone aggregate	1. Have an open bottom 2. Have a nominal pipe size of 4 inches 3. The lower 6 inches slotted 4. Slots are ≥ 1/4" and ≤ 1/2" in width and located on opposite sides 5. Anchored in a manner that will prevent the pipe from being pulled out 6. Extend from the infiltrative surface up to or above finish grade 7. Terminate with a removable watertight cap, or 8. Terminate with a vent cap if > 12 inches above finish grade

Table 3
OTHER SPECIFICATIONS
(continued)

Design and installation of observation pipes installed on leaching chambers	<ol style="list-style-type: none"> 1. Have an open bottom 2. Have a nominal pipe size of 4 inches 3. Anchored to the leaching chamber in a manner that will prevent the pipe from being pulled out 4. Extend from a distance \geq 4inches above the infiltrative surface through the top of the leaching chamber up to or above finish grade 5. Terminate with a removable watertight cap, or 6. Terminate with a vent cap if $>$ 12 inches above finish grade
Effluent application to distribution cell	<ol style="list-style-type: none"> 1. If DWF $<$ 1500 gpd, effluent may be applied by gravity flow, dosed to distribution cell or distribution box, then applied by gravity flow to the distribution cell, or by use of pressure distribution, unless pressure distribution is required in accordance with s. SPS 383.44 (5) (b) 2. If DWF \geq 1500 gpd, effluent must be dosed to distribution cell or distribution box, then applied by gravity flow to the distribution cell, or by use of pressure distribution, unless pressure distribution is required in accordance with s. SPS 383.44 (5) (b), Wis. Adm. Code
Septic tank effluent pump system	Meets requirements of s. SPS 384.10, Wis. Adm. Code and this manual

Table 3
OTHER SPECIFICATIONS
(continued)

<p>Dose tank or compartment volume employing one pump</p>	<p>\geq Volume of a single dose + reserve capacity^a + drain back volume^b + (6 inches x average gal/inch of tank)^c</p> <p>Notes: a: Reserve capacity \geq the estimated daily flow. b: Drain back volume \geq volume of wastewater that will drain into the dose tank from the distribution cell. c: Four inches of this dimension \geq vertical distance from pump intake to bottom of tank. Two inches of this dimension \geq vertical distance between pump on elevation and high water alarm activation elevation.</p>
<p>Dose tank or compartment volume employing duplex pumps</p>	<p>\geq Volume of a single dose + drain back volume^a + (6 inches x average gal/inch of tank)^b</p> <p>Notes: a: Drain back volume \geq volume of wastewater that will drain into the dose tank from the force main. b: Four inches of this dimension \geq vertical distance from pump intake to bottom of tank. Two inches of this dimension \geq vertical distance between pump on elevation and high water alarm activation elevation.</p>
<p>Siphon tank or compartment volume</p>	<p>\geq What is required to accommodate volumes necessary to provide dosing as specified in this manual</p>
<p>Distribution network for pressurized distribution systems. Note: Pressure distribution is required when soils or effluent meets parameters of s. SPS 383.44 (5), Wis. Adm. Code.</p>	<p>By use of pressure distribution network conforming with the sizing methods of either Small Scale Waste Management Project publication 9.6, entitled “Design of Pressure Distribution Networks for Septic Tank – Soil Absorption Systems” or Dept. of Safety and Professional Services publication SBD-10706, entitled Pressure Distribution Component Manual for Private Onsite Wastewater Treatment Systems”.</p>

Table 3
OTHER SPECIFICATIONS
(continued)

Vent pipes installed in stone aggregate system	<ol style="list-style-type: none"> 1. Connect to a gravity flow distribution lateral by the use of a fitting 2. Have a nominal pipe size of 4 inches 3. Extend from the distribution lateral > 12 inches above finish grade 4. Terminate in a manner that will allow a free flow of air between the distribution lateral and the atmosphere 5. The vent opening port is downward
Vent pipes installed on leaching chambers	<ol style="list-style-type: none"> 1. Anchored to the leaching chamber in a manner that will prevent the pipe from being pulled up 2. Have an open bottom 3. Have a nominal pipe size of 4 inches 4. Extend from inside of the leaching chamber \geq 12 inches above finish grade 5. Terminate in a manner that will allow a free flow of air between the leaching chamber and the atmosphere 6. The vent opening port is downward
Combination observation/vent pipes installed in a stone aggregate system	<p>Meets all of the requirements of observation pipes with the following exceptions:</p> <ol style="list-style-type: none"> 1. Have a minimum 4 inch pipe connection to a distribution lateral 2. Connect to the vent pipe at a point above the stone aggregate 3. Extend from the infiltrative surface \geq 12 inches above finish grade 4. Terminate in a manner that will allow a free flow of air between the distribution lateral and the atmosphere 5. The vent opening port is downward
Combination observation/vent pipes installed on a leaching chamber	<p>Meets all of the requirements of observation pipes with the following exceptions:</p> <ol style="list-style-type: none"> 1. Extend from the infiltrative surface \geq 12 inches above finish grade 2. Terminate in a manner that will allow a free flow of air between the leaching chamber and the atmosphere 3. The vent opening port is downward

Table 3
OTHER SPECIFICATIONS
(continued)

Cover material over the geotextile fabric or leaching chamber	Soil that will provide frost protection, prevent erosion and excess precipitation or runoff infiltration and allow air to enter the distribution cell
Installation inspection	In accordance with ch. SPS 383, Wis. Adm. Code
Management	In accordance with ch. SPS 383, Wis. Adm. Code and this manual

II. DEFINITIONS

Definitions not found in this section, are located in ch. SPS 381 of the Wisconsin Administrative Code or the terms use the standard dictionary definition.

- A. “Cobbles” means rock fragments greater than 3 inches, but less than 10 inches in diameter.
- B. “Septic tank effluent pump system” means a septic tank which has a pump installed in the tank that will pump effluent from the clear zone.
- C. “Site plan” means a scaled or completely dimensioned drawing, drafted by hand or computer aided technology, presented in a permanent form that shows the relative locations of setback encumbrances to a regulated object. The site plan also includes a reference to north, the size of the parcel on which the regulated object is placed, and permanent vertical and horizontal reference point or benchmark.
- D. “Stones” means rock fragments greater than 10 inches in diameter, but less than 24 inches.

III. DESCRIPTION AND PRINCIPLE OF OPERATION

POWTS conventional in situ soil component operation is a two-stage process involving both wastewater treatment and dispersal. Treatment is accomplished predominately by physical and biochemical processes within the treatment/dispersal zone. The physical characteristics of the influent wastewater, influent application rate, temperature, and the nature of the receiving soil affect these processes.

Physical entrapment, increased retention time, and conversion of pollutants in the wastewater are important treatment objectives accomplished under unsaturated soil conditions. Pathogens contained in the wastewater are eventually deactivated through filtering, retention, and adsorption by in situ soil.

Dispersal is primarily affected by the depth of the unsaturated receiving soil, the soil’s hydraulic conductivity, influent application rate, land slope, and the area available for dispersal.

The in-ground soil absorption component consists of a distribution cell. Influent is discharged to the distribution cell where it flows through the void area formed by aggregate and perforated pipe or leaching chambers and then passes into the underlying in situ soil for treatment and dispersal to the environment. The soil, to the prescribed depth, beneath the distribution cell is considered part of the cell known as the treatment/dispersal zone. See Figures 1 & 2.

Cover material over the geotextile fabric or leaching chamber is to provide frost protection, prevent erosion protection, a barrier to excess precipitation or runoff infiltration, and allows oxygen transfer.

The in situ soil within the treatment/dispersal zone provides the physical and biochemical treatment for the influent.

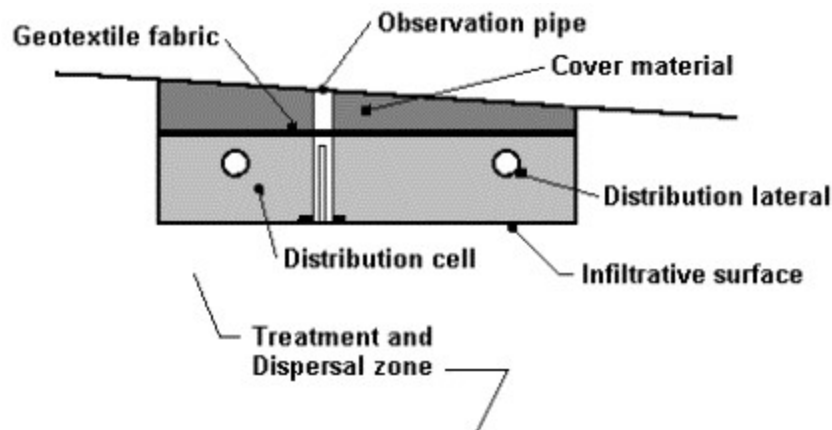

Figure 1 – Cross-section of an in-ground soil absorption component with multiple laterals

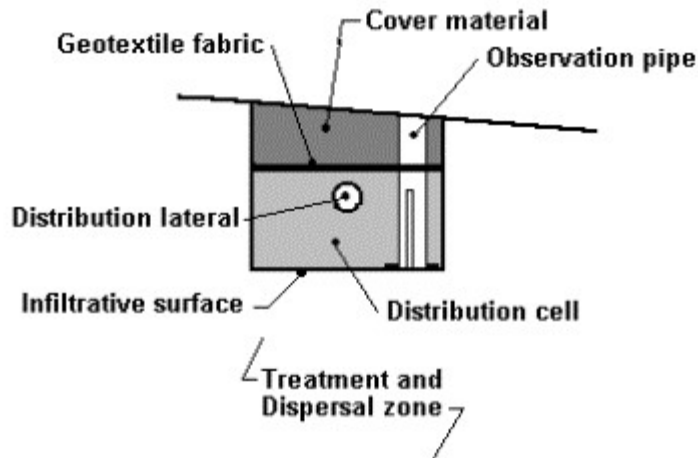

Figure 2 – Cross-section of an in-ground soil absorption component with a single lateral

IV. SOIL AND SITE REQUIREMENTS

Every in-ground soil absorption component design is ultimately matched to the given soil and site.

The design approach presented in this manual is based on criteria that all applied wastewater is successfully transported away from the system, that it will not affect subsequent wastewater additions, and that the effluent is ultimately treated, and that reaeration of the infiltrative surface will occur.

A. Minimum Soil Depth Requirements –

The minimum soil factors required for successful in-ground soil absorption component performance are listed in the introduction and specification section of this manual.

Soil evaluations must be in accordance with ch. SPS 385 of the Wis. Adm. Code. In addition, soil application rates must be in accordance with ch. SPS 383 of the Wis. Adm. Code.

B. Other Site Considerations -

1. In-ground soil absorption component location - In open areas, exposure to sun and wind increases the assistance of evaporation and transpiration in the dispersal of the wastewater.
2. Sites with trees and large boulders - Generally, sites with large trees, numerous smaller trees or large boulders are less desirable for installing an in-ground soil absorption component because of difficulty in preparing the distribution cell area. As with rock fragments, tree roots, stumps and boulders occupy area, thus reducing the amount of soil available for proper treatment. If no other site is available, trees in the distribution cell area must be removed.
3. Setback distances - The setbacks specified in ch. SPS 383, Wis. Adm. Code for soil subsurface treatment/dispersal component apply to in-ground soil absorption components. The distances are measured from the edge of the distribution cell area.

V. COVER MATERIAL

The cover material is of such quality and is placed so that it will not damage either the geotextile fabric or the leaching chambers. Clays are not recommended as they can restrict oxygen transfer. The cover material must not be compacted while being placed since compaction will reduce vegetative growth and oxygen transfer.

VI. DESIGN

A. Location, Size and Shape

Placement, sizing and geometry of the component must be in accordance with this manual.

B. Component Design

Design of the component is based upon the DWF and the soil characteristics. It must be sized such that it can accept the daily wastewater flow without causing surface seepage or groundwater pollution. Consequently, the surface area of the treatment and dispersal zone, which is the in situ soil area beneath the component, must be sufficiently large enough to absorb the applied effluent into the underlying soil. The component must also be designed to avoid encroachment of the water table into the treatment and dispersal zone.

Design of the component includes three major steps, which are: (A) calculating DWF, (B) calculating soil infiltration area, and (C) design of the distribution cell. Each step is discussed below.

Step A: Design Wastewater Flow Calculations

One- and two-family dwellings. Distribution cell size for one and two-family dwelling application is determined by calculating the design wastewater flow (DWF). To calculate DWF use, Formulas 1, 2 or 3. Formula 1 is for combined wastewater flows, which consist of blackwater, clearwater and graywater. Formula 2 is for only clearwater and graywater. Formula 3 is blackwater only.

Formula 1 Combined wastewater DWF = 150 gal/day/bedroom	Formula 2 Clearwater & Graywater DWF = 90 gal/day/bedroom	Formula 3 Blackwater DWF = 60 gal/day/bedroom
---	---	---

Public Facilities. Distribution cell size for public facilities application is determined by calculating the DWF using Formula 2. Public facility estimated daily wastewater flows can be found in s. SPS 383.43(6), Wis. Adm. Code. Facilities not listed in s. SPS 383.43(6), Wis. Adm. Code can be discussed with the plan reviewer to establish an acceptable daily flow rate volume. Many commercial facilities have high BOD₅, TSS and FOG (fats, oils and grease), which must be pretreated in order to bring their values down to an acceptable range before entering into the at-grade component described in this manual.

Formula 2

$$\text{DWF} = \text{Sum of each wastewater flow per source per day (from Table 4)} \times 1.5$$

Where 1.5 = Conversion factor to convert estimated wastewater flow to design wastewater flow.

Step B: Sizing the Distribution Cell Area

The required distribution cell area is based on the DWF and the slowest soil application rate of the in situ soil at the infiltrative surface or a lower horizon if the lower horizon adversely affects the dispersal of wastewater in accordance with s. SPS 383.44 (4) (a) and (c), Wis. Adm. Code. Wastewater application rates to the soil are found in ch. SPS 383, Wis. Adm. Code.

Using the above information, the required distribution cell area can be determined using the following formula:

Area = DWF ÷ Lowest application rate of the in situ soil in accordance with s. SPS 383.44 (4) (a) and (c), Wis. Adm. Code. Note: This area may include the area of more than one distribution cell.

Step C: Component Configuration

The maximum distribution cell width is 6 feet. The maximum length and width of the distribution cell is dependent on setback requirements of s. SPS Table 383.43-1, Wis. Adm. Code, and soil evaluation results.

Where possible, on sloping sites, the distribution cell is aligned with its longest dimension parallel to the land surface contours so as not to concentrate the effluent into a small area as it moves vertically and horizontally down slope.

Distribution Cell Height

The distribution cell height provides wastewater storage and support of the piping within the distribution cell. The minimum height of the distribution cell, when aggregate is used in gravity distribution components is 12 inches or 9 inches when pressure distribution is used. This provides a minimum space of 6 inches beneath the distribution pipe and 2 inches above the distribution piping, as specified in the specification section of this package. See figure 3. The minimum depth of the distribution cell when leaching chambers are used is equal to the height of the leaching chamber. See figure 4.

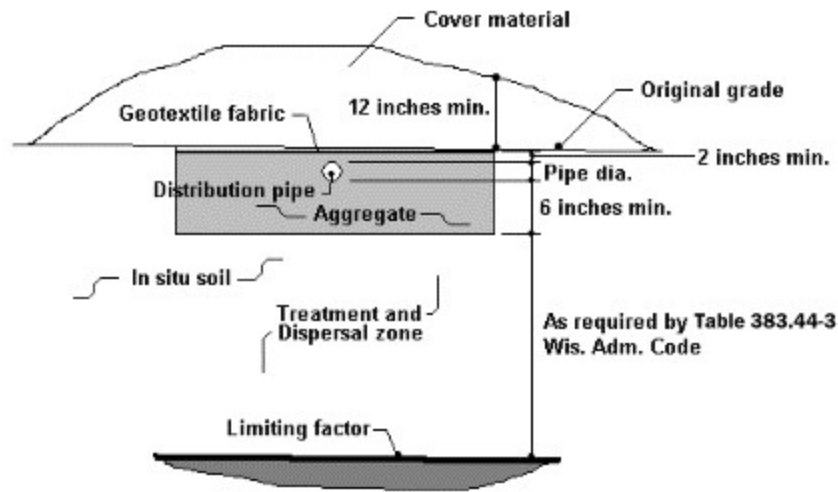

Figure 3 - Height of system when using aggregate.

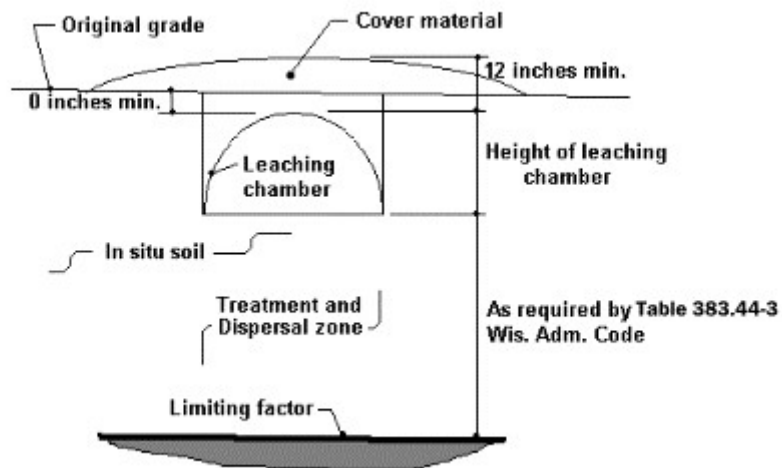

Figure 4 - Height of system using leaching chambers

Cover Material

A minimum of 12 inches of cover material must be placed over the top of the geotextile fabric or leaching chamber. Finished grade of the cover material must be at or above the surrounding land surface elevation. Depressional areas over the distribution cell that collect and retain surface water runoff must be avoided.

Distribution Network and Dosing Component

The effluent application to the distribution cell may be by gravity or pressure and may consist of piping or leaching chambers. Distribution boxes or drop boxes may be used to distribute effluent to gravity feed distribution cells. Distribution piping for a gravity component has a nominal inside diameter of 4 inches. The distribution header is non perforated pipe. The slope of gravity flow perforated distribution piping is less than or equal to 4 inches per 100 feet away from distribution boxes, drop boxes or header. When a drop box design is used, the invert of the drop box overflow pipe must be at least 4 inches lower than the invert of the treatment tank outlet or force main connection.

The design and installation of distribution boxes must be watertight and capable of providing a means of providing equal distribution of effluent to each distribution cell. Drop boxes must be watertight and capable of distributing effluent to another distribution cell.

Components that are designed to receive a DWF greater than 1500 gal/day, dose the effluent to the distribution cell by means of a pump or siphon. The dose chamber shall contain sufficient volume to dose the distribution cell as required by its system design, retain drain back volume, contain a one day reserve zone, provide a minimum 2 inch separation between alarm activation and pump-on activation, and allow for protection of the pump from solids.

Drain back volumes can be calculated based on values listed in Table 5.

Nominal Pipe Size	Gallons per Foot
1 – 1/4	0.064
1 – 1/2	0.092
2	0.163
3	0.367
4	0.65
6	1.469

Note a: Table is based on $-\pi(d/2)^2 \times 12''/\text{ft} \div 231 \text{ cu.in./cu.ft}$

Where: d = nominal pipe size in inches

A reserve capacity is required on a system with only one pump. The reserve volume must be equal to or greater than the estimated daily wastewater flow. Reserve capacity may be calculated using 100 gallons per bedroom per day for one- and two-family residences or the values computed by using Table 4.

The dose volume shall be included in the sizing of the dose chamber. (Volume of a septic tank effluent pump system is determined by department plumbing product approval.)

The pump alarm activation point must be at least 3 inches above the pump activation point.

Allow “dead” space below the pump intake to permit the settling of solids in the dose chamber. This can be accomplished by placing the pump on concrete blocks or other material that can form a pedestal.

The pump manufacturer’s requirements shall be followed. This may include the “pump off” switch being located high enough to allow for complete immersion of the pump in the dose chamber.

Leaching chamber tops are at or below the original grade. Leaching chambers are placed directly on the bottom of the distribution cell. If the distribution cell has more than one row of chambers the rows are side by side and in contact with each other.

Observation pipes are installed in the distribution cells and are provided with a means of anchoring to prevent them from being lifted up. Observation pipes extend from the infiltrative surface for stone aggregate systems or from the inside of leaching chambers to a point at or above finish grade. The portion of the observation pipe below the distribution pipe for stone aggregate systems is slotted while the portion above the distribution pipe is solid wall. Observation pipes for leaching chamber systems are attached to the chambers in accordance with the chamber manufacturer’s printed instructions, extend from a distance ≥ 4 inches above the infiltrative surface through the top of the leaching chamber up to or above finish grade and terminate with a removable watertight cap. All observation piping has a nominal pipe size of 4 inches. See Figure 5.

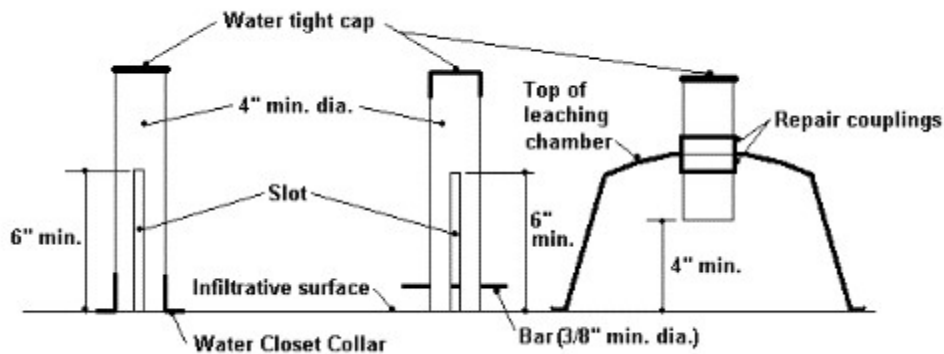

Figure 5 - Observation pipes

Vent pipes, if installed, connect to the upper half of the gravity flow distribution laterals and extend up to at least 12 inches above finish grade. Vent pipes terminate with the vent opening facing downward by the means of a vent cap or fittings. Vent caps must allow a free flow of air between the distribution lateral and the atmosphere. All vent pipes have a nominal pipe size of 4 inches.

When a vent pipe is connected to an observation pipe, the point of connection shall be made at a point above the stone aggregate for stone aggregate systems and terminate as required for vent pipes.

An observation pipe may serve as a combination observation/vent pipe providing it terminates in the same manner as required for vent pipes. See Figure 6.

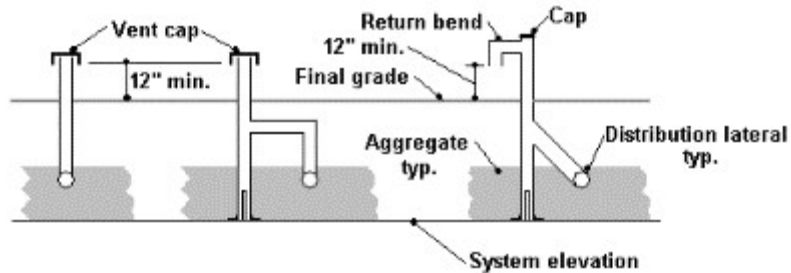

Figure 6 – Vent and combination observation/vent pipes

VII. SITE PREPARATION AND CONSTRUCTION

Procedures used in the construction of an in-ground soil absorption component are just as critical as the design of the component. A good design with poor construction, results in component failure. It is emphasized that the soil only be worked when the moisture content is low to avoid compaction and smearing. Consequently, installations are to be made only when the soil is dry enough to prevent compaction and smearing of the infiltrative surface. The construction plan to be followed includes:

A. Equipment - Proper equipment includes tractors or other equipment that will not compact the infiltrative surface. Minimize foot traffic on infiltrative surface and avoid equipment traffic on or over infiltrative surface.

B. Sanitary Permit - Prior to the construction of the component, a sanitary permit, obtained for the installation must be posted in a clearly visible location on the site. Arrangements for inspection(s) must also be made with the department or governmental unit issuing the sanitary permit.

C. Construction Procedures

1. Check the moisture content and condition of the soil. If the soil at the infiltrative surface can be rolled into a 1/4-inch wire, the site is too wet, smearing and compaction will result, thus reducing the infiltrative capacity of the soil. If the site is too wet, do not proceed until it dries out. If the soil at or below the infiltrative surface is frozen, do not proceed.
2. Set up a construction level or similar device and determine all relative elevations in relationship to the benchmark. It is necessary to determine the bottom elevation of the distribution cell, land surface contour lines, and approximate component elevations critical to the installation.

3. Lay out the absorption area within the tested designated area. Where possible lay out the absorption areas(s) on the site so that the distribution cell runs parallel with the land surface contours. Reference stakes offset from the corner stakes are recommended in case corner stakes are disturbed during construction.
4. Excavate the distribution cell(s) to the correct bottom elevation(s) taking care not to smear the infiltrative surface. If the infiltrative surface is smeared, loosen it with the use of a rake or similar device. The infiltration surface can be left rough and should not be raked smooth.
5. Install observation pipes with the bottom 6 inches of the pipe slotted for components using stone aggregate. When leaching chambers are installed, the observation pipe connects to the top of the leaching chamber. Installation of the observation pipe includes a suitable means of anchoring so the pipes are not dislodged during inspections. Observation pipes will be installed in each distribution cell so as to be representative of a cell's hydraulic performance. Flexibility in location allows that observation pipes: be located such that there are a minimum of two installed in each dispersal cell at opposite ends from one another; be located near the dispersal cell ends; be at least 6 inches from the end wall and sidewall; and be installed at an elevation to view the horizontal or level infiltrative surface within the dispersal cell. Observation pipes may be located less than 6 inches from end walls or side walls if specified in state-approved manufacturers' installation instructions.
6. If stone aggregate is used, place it into the excavation until the top of the aggregate is at the elevation of the distribution piping. Placement of the stone aggregate is done in such a manner as not to compact the infiltrative surface. If leaching chambers are used, install the leaching chambers in accordance with the manufacturers' installation instructions.
7. Place the distribution pipes, as determined from the design, on stone the aggregate. Connect the distribution box, drop box or manifold to the pipe from the treatment or dosing chamber.
8. Install vent pipe, if one is to be installed as prescribed in Table 3.
9. If stone aggregate is used, place stone aggregate over the distribution pipe and the entire distribution cell until the elevation of the stone aggregate is at least 2 inches above the top of the distribution pipe.
10. If stone aggregate is used, place geotextile fabric conforming to requirements of ch. SPS 384, Wis. Adm. Code, over the aggregate.
11. Place the cover material on top of the geotextile fabric and/or leaching chamber. Avoid backfilling the first 12 inches with cobbles, stones, or frozen material that could damage pipe, chamber or fabric.

VIII. OPERATION, MAINTENANCE AND PERFORMANCE MONITORING

- A. The component owner is responsible for the operation and maintenance of the component. The county, department or POWTS service contractor may make periodic inspections of the components, checking for surface discharge, wastewater levels, etc.

The owner or owner's agent is required to submit necessary maintenance reports to the appropriate jurisdiction and/or the department.

- B. Design approval and site inspections before, during, and after the construction are accomplished by the county or other appropriate jurisdictions in accordance to ch. SPS 383, Wis. Adm. Code.

- C. Routine and preventative maintenance aspects:

1. Treatment and distribution tanks are to be inspected routinely and maintained when necessary, in accordance with the applicable plan or product approval.
2. Inspections of the in-ground soil absorption component performance are required at least once every three years. These inspections include checking the liquid levels in the observation pipes and examination for any seepage around the in-ground soil absorption component.
3. Winter traffic on the in-ground soil absorption component is not permitted to avoid frost penetration and to minimize compaction.
4. A good water conservation plan within the house or establishment will help assure that the in-ground soil absorption component will not be overloaded.

- D. User's Manual: A user's manual is to accompany the component. The manual is to contain the following as a minimum:

1. Diagrams of all component components and their location. This should include the location of the reserve area, if one is provided.
2. Names and phone numbers of local health authority, component manufacturer or POWTS service contractor to be contacted in the event of component failure or malfunction.
3. Information on the periodic maintenance of the component, including electrical/mechanical components.
4. What activities can or cannot occur on the reserve area, if one is provided.

- E. Performance monitoring must be performed on components installed under this manual.

1. The frequency of monitoring must be:
 - a. At least once every three years following installation, and

- b. At time of a problem, complaint, or failure.
2. The minimum criteria addressed in performance monitoring of components are:
- a. Type of use,
 - b. Age of component,
 - c. Type of component, dosed or gravity feed,
 - d. Nuisance factors, such as odors or user complaints,
 - e. Mechanical malfunction within the component including problems with valves or other mechanical or plumbing components,
 - f. Material fatigue or failure, including durability or corrosion as related to construction or structural design,
 - g. Neglect or improper use, such as overloading the design rate, poor maintenance of vegetative cover, inappropriate cover over the component, or inappropriate activity over the component,
 - h. Pretreatment component maintenance, including dosing frequency, structural integrity, groundwater intrusion or improper sizing,
 - i. Pump or siphon chamber maintenance, including improper maintenance, infiltration, structural problems, or improper sizing,
 - j. Ponding in distribution cell, prior to the pump cycle,
 - k. Siphon or pump malfunction including dosing volume problems, breakdown, burnout, or cycling problems, and
 - l. Overflow/seepage problems, as shown by evident or confirmed sewage effluent, including backup.
3. Reports are to be submitted in accordance to ch. SPS 383, Wis. Adm. Code.

IX. REFERENCES

R.J. Otis, G.D. Plews and D.H. Patterson. "Design of Conventional Soil Absorption Trenches and Beds." In: Home Sewage Treatment, Proceeding of the Second National Home Sewage Treatment Symposium, ASAE Publication 5-77.

United States EPA, EPA 625/1-80-012, October 1980. "Design Manual – Onsite Wastewater Treatment and Disposal Systems."

X. IN-GROUND SOIL ABSORPTION COMPONENT WORKSHEET

IN-GROUND SOIL ABSORPTION COMPONENT WORKSHEET

A. SITE CONDITIONS

Evaluate the site and soils report for the following:

- Surface water movement.
- Measure elevations and distances on the site so that slope, contours and available areas can be determined.
- Description of several soil profiles where the system will be located.
- Determine the limiting conditions such as bedrock, high groundwater level, soil permeability, and setbacks.

Slope - ____%

Occupancy: One- or Two-family Dwelling- ____ (# of bedrooms)

Public Facility - ____ gal/day (Estimated wastewater flow)

Depth to limiting factor - ____ inches

Minimum depth of unsaturated soil required by Table 383.44-3, Wis. Adm. Code - ____ inches

Soil application rate of in situ soil used - ____ gal/ft²/day

FOG value of effluent applied to component - ____ mg/L

BOD₅ value of effluent applied to component - ____ mg/L

TSS value of effluent applied to component - ____ mg/L

Fecal Coliform monthly geometric mean value of effluent applied to component >10⁴cfu/100ml - ____ Yes ____ No

Type of distribution cell - ____ Stone aggregate or ____ Leaching chamber

B. DESIGN WASTEWATER FLOW (DWF)

One- or Two-family Dwelling

Combined wastewater flow:

DWF = 150 gal/day/bedroom x # of bedrooms

= 150 gal/day/bedroom x ____ # of bedrooms

= _____ gal/day

Clearwater and graywater only:

$$\begin{aligned} \text{DWF} &= 90 \text{ gal/day/bedroom} \times \# \text{ of bedrooms} \\ &= 90 \text{ gal/day/bedroom} \times \underline{\hspace{2cm}} \# \text{ of bedrooms} \\ &= \underline{\hspace{2cm}} \text{ gal/day} \end{aligned}$$

Blackwater only:

$$\begin{aligned} \text{DWF} &= 60 \text{ gal/day/bedroom} \times \# \text{ of bedrooms} \\ &= 60 \text{ gal/day/bedroom} \times \underline{\hspace{2cm}} \# \text{ of bedrooms} \\ &= \underline{\hspace{2cm}} \text{ gal/day} \end{aligned}$$

Public Facility

$$\begin{aligned} \text{DWF} &= \text{Estimated wastewater flow} \times 1.5 \\ &= \underline{\hspace{2cm}} \text{ gal/day} \times 1.5 \\ &= \underline{\hspace{2cm}} \text{ gal/day} \end{aligned}$$

C. WIDTH AND LENGTH OF THE DISTRIBUTION CELL.

1. Determine the design loading rate (DLR) for the site.

From Table 383.44-1 or-2, Wis. Adm. Code, select the soil application rate for the most restrictive soil horizon at the infiltrative surface or a lower horizon if the lower horizon adversely affects the dispersal of wastewater in accordance with s. SPS 383.44 (4) (a) and (c). The design loading rate (DLR) is the soil application rate selected from Table 383.44-1 or-2, Wis. Adm. Code, unless the component consists of products that have been recognized through s. SPS 384.50, Wis. Adm. Code, as having a different soil application rate.

$$\text{DLR} = \underline{\hspace{2cm}} \text{ gpd/ft}^2$$

2. Determine the distribution cell area.

Calculate the distribution cell area by dividing the daily design wastewater flow (DWF) by the design loading rate (DLR).

$$\begin{aligned} \text{Distribution cell area} &= \text{DWF} \div \text{DLR} \\ \text{Distribution cell area} &= \underline{\hspace{2cm}} \text{ gpd} \div \underline{\hspace{2cm}} \text{ gpd/ft}^2 \\ \text{Distribution cell area} &= \underline{\hspace{2cm}} \text{ ft}^2 \end{aligned}$$

3. Select a width (A) for the distribution cell. The width of the distribution cell cannot exceed 6 feet.

$$A = \underline{\hspace{1cm}} \text{ ft}$$

4. Determine the distribution cell length.

Calculate the distribution cell length (B) by dividing the required distribution area by the distribution cell width (A).

$$B = \text{Distribution cell area} \div A$$

$$B = \underline{\hspace{1cm}} \text{ ft}^2 \div \underline{\hspace{1cm}} \text{ ft}$$

$$B = \underline{\hspace{1cm}} \text{ ft}$$

XI. EXAMPLE WORKSHEET

IN-GROUND SOIL ABSORPTION COMPONENT WORKSHEET

A. SITE CONDITIONS

Evaluate the site and soils report for the following:

- Surface water movement.
- Measure elevations and distances on the site so that slope, contours and available areas can be determined.
- Description of several soil profiles where the system will be located.
- Determine the limiting conditions such as bedrock, high groundwater level, soil permeability, and setbacks.

Slope - ___%

Occupancy: One- or Two-family Dwelling - 4 (# of bedrooms)

Public Facility - _____ gal/day (Estimated wastewater flow)

Depth to limiting factor - 60 inches

Minimum depth of unsaturated soil required by Table 383.44-3, Wis. Adm. Code - 36 inches

Soil application rate of in situ soil used - 0.8 gal/ft²/day

FOG value of effluent applied to component - 20 mg/L

BOD₅ value of effluent applied to component - 180 mg/L

TSS value of effluent applied to component - 120 mg/L

Fecal Coliform monthly geometric mean value of effluent applied to component >10⁴cfu/100ml - ___ Yes ___ No

Type of distribution cell - X Stone aggregate or ___ Leaching chamber

B. DESIGN WASTEWATER FLOW (DWF)

One- or Two-family Dwelling.

Combined wastewater flow:

DWF = 150 gal/day/bedroom x # of bedrooms

= 150 gal/day/bedroom x 4 # of bedrooms

= 600 gal/day

Clearwater and graywater only:

$$\begin{aligned} \text{DWF} &= 90 \text{ gal/day/bedroom} \times \# \text{ of bedrooms} \\ &= 90 \text{ gal/day/bedroom} \times \underline{\hspace{2cm}} \# \text{ of bedrooms} \\ &= \underline{\hspace{2cm}} \text{ gal/day} \end{aligned}$$

Blackwater only:

$$\begin{aligned} \text{DWF} &= 60 \text{ gal/day/bedroom} \times \# \text{ of bedrooms} \\ &= 60 \text{ gal/day/bedroom} \times \underline{\hspace{2cm}} \# \text{ of bedrooms} \\ &= \underline{\hspace{2cm}} \text{ gal/day} \end{aligned}$$

Public Facility

$$\begin{aligned} \text{DWF} &= \text{Estimated wastewater flow} \times 1.5 \\ &= \underline{\hspace{2cm}} \text{ gal/day} \times 1.5 \\ &= \underline{\hspace{2cm}} \text{ gal/day} \end{aligned}$$

C. WIDTH AND LENGTH OF THE DISTRIBUTION CELL.

1. Determine the design loading rate (DLR) for the site.

From Table 383.44-1 or-2, Wis. Adm. Code, select the soil application rate for the most restrictive soil horizon at the infiltrative surface or a lower horizon if the lower horizon adversely affects the dispersal of wastewater in accordance with s. SPS 383.44 (4) (a) and (c). The design loading rate (DLR) is the soil application rate selected from Table 383.44-1 or-2, Wis. Adm. Code, unless the component consists of products that have been recognized through s. SPS 384.50, Wis. Adm. Code, as having a different soil application rate.

$$\text{DLR} = \underline{0.8} \text{ gpd/ft}^2$$

2. Determine the distribution cell area.

Calculate the distribution cell area by dividing the daily design wastewater flow (DWF) by the design loading rate (DLR).

$$\begin{aligned} \text{Distribution cell area} &= \text{DWF} \div \text{DLR} \\ \text{Distribution cell area} &= \underline{600} \text{ gpd} \div \underline{0.8} \text{ gpd/ft}^2 \\ \text{Distribution cell area} &= \underline{750} \text{ ft}^2 \end{aligned}$$

3. Select a width (A) for the distribution cell. The width of the distribution cell cannot exceed 6 feet.

$$A = \underline{6} \text{ ft}$$

4. Determine the distribution cell length.

Calculate the distribution cell length (B) by dividing the required distribution area by the distribution cell width (A).

$$B = \text{Distribution cell area} \div A$$

$$B = \underline{750} \text{ ft}^2 \div \underline{6} \text{ ft}$$

$$B = \underline{125} \text{ ft}$$

XII. PLAN SUBMITTAL AND INSTALLATION INSPECTION

A. Plan Submittal

In order to install a system correctly, it is important to develop plans that will be used to install the system correctly the first time. The following checklist may be used when preparing plans for review. The checklist is intended to be a **general guide**. Not all needed information may be included in this list. Some of the information listed may not be required to be submitted due to the design of the system. Conformance to the list is not a guarantee of plan approval. Additional information may be needed or requested to address unusual or unique characteristics of a particular project. Contact the reviewing agent for specific plan submittal requirements, which the agency may require that are different than the list included in this manual.

General Submittal Information

- Photocopies of soil reports forms, plans, and other documents are acceptable. However, an original signature is required on certain documents.
- Submittal of additional information requested during plan review or and questions concerning a specific plan must be referenced to the Plan Identification indicator assigned to that plan by the reviewing agency.
- Plans or documents must be permanent copies or originals.

Forms and Fees

- Application form for submittal, provided by reviewing agency along with proper fees set by reviewing agent.

Soils information

- Complete Soils and Site Evaluation Report (form # SBD-8330) for each soil boring described; signed and dated by a certified soil tester, with credential number.
- Separate sheet showing the location of all borings. The location of all borings and backhoe pits must be able to be identified on the plot plan.

Documentation

- Architects, engineers or designers must sign, seal and date each page of the submittal or provide an index page, which is signed, sealed and dated.
- Master Plumbers must sign, date and include their license number on each page of the submittal or provide an index page, which is signed, sealed and dated.
- Submittals, if paper, must measure at least 8-1/2 by 11 inches.
- Designs that are based on department approved component manual(s) must include reference to the manual by name, publication number and published date.

Plot Plan

- Dimensioned plans or plans drawn to scale (scale indicated on plans) with parcel size or all property boundaries clearly marked.

- Slope directions and percent in system area.
- Benchmark and north arrow.
- Setbacks indicated as per appropriate code.
- Two-foot contours or other appropriate contour interval within the system area.
- Location information; legal description of parcel must be noted.
- Location of any nearby existing system or well.

Plan View

- Dimensions for distribution cell(s).
- Location of observation pipes and vent pipes.
- Pipe lateral layout, which must include the number of laterals, pipe material, diameter and length; and number, location and size of orifices.
- Distribution boxes, drop boxes, manifold and force main locations, with materials, length and diameter of all pipes.

Cross Section of System

- Lateral elevation, position of observation pipes, dimensions of distribution cell, and type of cover material such as geotextile fabric, if applicable.
- Distribution cell details.
- Minimum and maximum depths of top of the distribution cell or chamber below original and final grades.

System Sizing

- For one- and two-family dwellings the number of bedrooms must be included.
- For public buildings, the sizing calculations must be included.

Tank and Pump / Siphon Information

- Cross section and all construction details for site-constructed tanks.
- Size and manufacturer information for prefabricated tanks.
- Notation of pump or siphon model, pump performance curve, friction loss for force main and calculation for total dynamic head.
- Notation of alarm manufacturer and model number.
- Cross section of dose tank / chamber to include storage volumes; connections for piping, vents, and power; pump “off” setting; dosing cycle and volume; high water alarm setting, and storage volume above the highwater alarm; and location of vent and manhole.
- Cross section of two compartments tanks or tanks installed in a series must include information listed above.

B. Inspections

Inspection shall be made in accordance with ch. 145.20, Wis. Stats and s. SPS 383.26, Wis. Adm. Code. The inspection form on the following two pages may be used. The inspection of the system installation and/or plans is to verify that the system at least conforms to specifications listed in Tables 1 - 3 of this manual.

Do your Part— Be SepticSmart!

A Homeowners' Guide to Septic Systems



**septicSMART**

U.S. Environmental Protection Agency

Maintaining Your Septic System:

Good for your wallet. Good for your health. Good for the environment.

Did you know that one-quarter of all U.S. homes have septic systems? Yours may be one of them. If you're not properly maintaining your septic system, you're not only hurting the environment, you're putting your family's health at risk—and may be flushing thousands of dollars down the drain!

First Things First:

What Is a Septic System?

Common in rural areas without centralized sewer systems, septic systems are underground wastewater treatment structures that use a combination of nature and time-tested technology to treat wastewater from household plumbing produced by bathrooms, kitchen drains, and laundry.

Do You Have a Septic System?

You may already know you have a septic system. If you don't know, here are tell-tale signs that you probably do:

- You use well water.
- The waterline coming into your home doesn't have a meter.
- You show a "\$0.00 Sewer Amount Charged" on your water bill.
- Your neighbors have a septic system.



How To Find Your Septic System

Once you've determined that you have a septic system, you can find it by:

- Looking on your home's "as built" drawing.
- Checking your yard for lids and manhole covers.
- Contacting a septic inspector/pumper to help you locate it.

Why Should You Maintain Your Septic System?

Maintaining Your Septic System...

Saves You Money

Regular maintenance fees of \$250 to \$300 every three to four years is a bargain compared to the cost of repairing or replacing a malfunctioning system, which can cost between \$3,000 and \$7,000. The frequency of pumping required for your system depends on how many people live in your home and the size of the system.

Protects Your Property Value

An unusable septic system or one in disrepair will lower your property value, not to mention pose a potentially costly legal liability.

Keeps You and Your Neighbors Healthy

Household wastewater is loaded with disease-causing bacteria and viruses, as well as high levels of nitrogen and phosphorus. If a septic system is well-maintained and working properly, it will remove most of these pollutants. Insufficiently treated sewage from septic systems can cause groundwater contamination, which can spread disease in humans and animals.

Improperly treated sewage also poses the risk of contaminating nearby surface waters, significantly increasing the chance of swimmers contracting a variety of infectious diseases, from eye and ear infections to acute gastrointestinal illness and hepatitis.

Service provider coming? Here's what you need to know.

When you call a septic service provider, he or she will inspect for leaks and examine the scum and sludge layers in your septic tank.

Your septic tank includes a T-shaped outlet which prevents sludge and scum from leaving the tank and traveling to the drainfield area. If the bottom of the scum layer is within six inches of the bottom of the outlet, or if the top of the sludge layer is within 12 inches of the outlet, your tank will need to be pumped. Remember to note the sludge and scum levels determined by the septic professional in your operation and maintenance records, as this will help determine how often pumping is necessary.

The service provider should note any repairs completed and the tank condition in your system's service report. If additional repairs are recommended, be sure to hire someone to make them as soon as possible.

The National Onsite Wastewater Recycling Association (NOWRA) website has a septic locator that makes it easy to service professionals in your area. Visit www.septiclocator.com and enter your ZIP code to get started!

Beware of septic tank additives!

Some makers of septic tank additives claim their products break down septic tank sludge in order to eliminate the need for pumping. But the effectiveness of additives has not been determined; in fact, many studies show that additives have no significant effects on a tank's bacterial populations.

Septic tanks already contain the microbes they need for the effective breakdown of household wastewater pollutants. Periodic pumping is the only true way to ensure that septic systems work properly and provide many years of service.

Protects the Environment

More than four billion gallons of wastewater is dispersed below the ground's surface every day. That's a lot of water! Groundwater contaminated by poorly or untreated household wastewater doesn't just pose dangers to drinking water—it poses dangers to the environment. Malfunctioning septic systems release bacteria, viruses, and chemicals toxic to local waterways. When these pollutants are released into the ground, they eventually enter streams, rivers, lakes, and more, harming local ecosystems by killing native plants, fish, and shellfish.

Maintaining Your Septic System:

The Basics

Septic system maintenance isn't complicated, and it doesn't need to be expensive. Upkeep comes down to four important elements:

- Inspection and pumping
- Water efficiency
- Proper waste disposal
- Drainfield care

Inspect and pump frequently

The average household septic system should be inspected at least every three years by a septic service professional. Household septic tanks are typically pumped every three to five years. Alternative systems with electrical float switches, pumps, or mechanical components need to be inspected more often, generally once a year. A service contract is important since alternative systems have mechanized parts.

Four major factors influence the frequency of septic pumping:

- Household size
- Total wastewater generated
- Volume of solids in wastewater
- Septic tank size



Use water efficiently

Did you know that average indoor water use in a typical single-family home is nearly 70 gallons per individual, per day? And just a single leaky toilet can waste as much as 200 gallons of water per day?

All of the water a household sends down its pipes winds up in its septic system. This means that the more water a household conserves, the less water enters the septic system. Efficient water use can not only improve the operation of a septic system, but it can reduce the risk of failure as well. Learn more about simple ways to save water and water-efficient products by visiting EPA's WaterSense Program at www.epa.gov/watersense.

- **High-efficiency toilets:** Toilet use accounts for 25 to 30 percent of household water use. Most older homes have toilets with 3.5- to 5-gallon reservoirs, while newer, high-efficiency toilets use 1.6 gallons of water or less per flush. Replacing existing toilets with high-efficiency models is an easy way to quickly reduce the amount of household water entering your septic system.
- **Faucet aerators and high-efficiency showerheads:** Faucet aerators help reduce water use as well as the volume of water entering your septic system. High-efficiency showerheads or shower flow restrictors also reduce water use.
- **Washing machines:** Washing small loads of laundry on your washing machine's large-load cycle wastes water and energy. By selecting the proper load size, you'll reduce water waste. If you're unable to select a load size, run only full loads of laundry.

Another tip? Try to spread water use via washing machine throughout the week. Doing all household laundry in one day might seem like a time-saver, but it can be harmful to your septic system, as it doesn't allow your septic tank time to adequately treat waste and could potentially flood your drainfield.

Consider purchasing an ENERGY STAR® clothes washer, which uses 35 percent less energy and a whopping 50 percent less water than a standard model. Learn more about ENERGY STAR appliances by visiting www.energystar.gov.

Small leaks can lead to big problems!

When it comes to water fixtures, a couple of quick fixes can save you serious problems down the road!

Check to see if your toilet's reservoir is leaking into your toilet bowl by adding five drops of liquid food coloring to the toilet reservoir before bed. If the dye is in the toilet bowl the next morning, the reservoir is leaking and repairs are needed.

Think a leaky faucet is no big deal? Think again. A small drip from a faucet adds gallons of unnecessary water to your septic system every day.

To see how much a leak adds to your water usage, place a cup under the drip for 10 minutes. Multiply the amount of water in the cup by 144 (the number of minutes in 24 hours, divided by 10). Just one cup of leaky faucet water every 10 minutes equals 36 wasted gallons of water a day—and they all end up in your septic system.

New faucets and toilet reservoirs are easily accessible and inexpensive. Choose to make a small investment for a big difference in your septic system.

- **Proper waste disposal:** Whether you flush it down the toilet, grind it in the garbage disposal, or pour it down the sink, shower, or bath, everything that goes down your drains ends up in your septic system. And what goes down the drain can have a major impact on how well your septic system works.

Toilets Aren't Trash Cans!

Your septic system is not a trash can. An easy rule of thumb? Don't flush anything besides human waste and toilet paper.

Never flush:

- Feminine hygiene products
- Condoms
- Dental floss
- Diapers
- Cigarette butts
- Coffee grounds
- Cat litter
- Household chemicals like gasoline, oil, pesticides, antifreeze, and paint
- Pharmaceuticals

For a complete list, visit water.epa.gov/septicsmart.

How does a septic system work?

This is a simplified overview of how a septic system works.

- 1 All water runs out of your house from one main **drainage pipe** into a septic tank.
- 2 The **septic tank** is a buried, water-tight container usually made of concrete, fiberglass or polyethylene. Its job is to hold the wastewater long enough to allow solids to settle down to the bottom (forming sludge), while the oil and grease floats to the top (as scum). Compartments and a T-shaped outlet prevent the sludge and scum from leaving the tank and traveling into the drainfield area.
- 3 The liquid wastewater then exits the tank into the **drainfield**. If the drainfield is overloaded with too much liquid, it will flood, causing sewage to flow to the ground surface or create backups in toilets and sinks.
- 4 Finally, the wastewater percolates into the **soil**, naturally removing harmful bacteria, viruses, and nutrients.

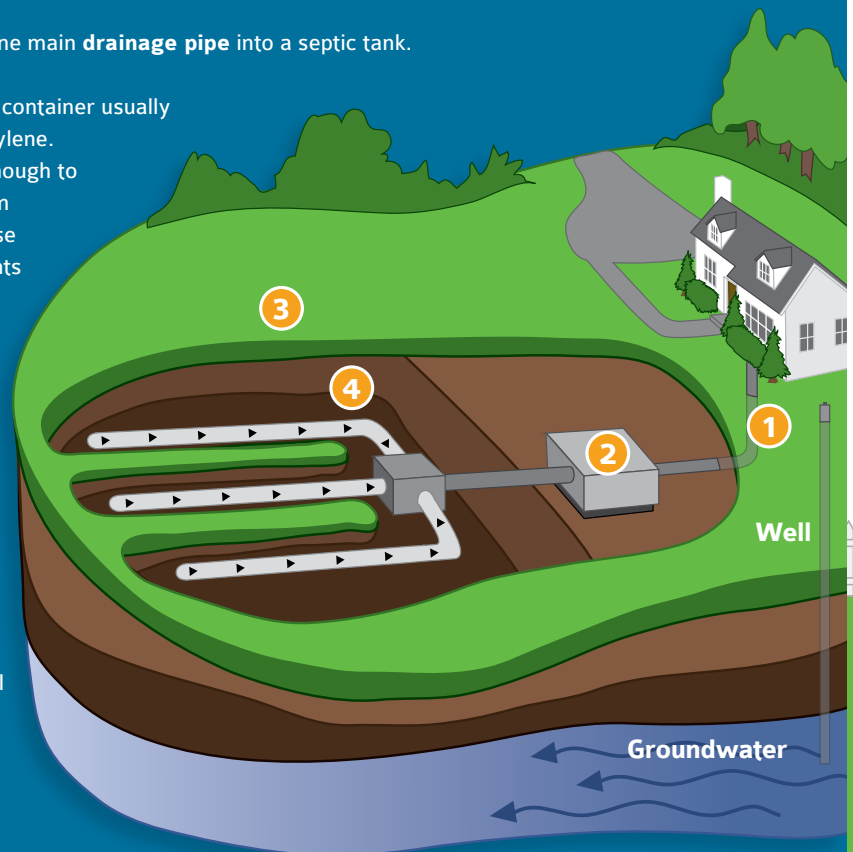

Own an RV, boat or mobile home?

If you spend any time in a recreational vehicle (RV) or boat, you probably know of the problem of odors from sewage holding tanks. Learn more about proper and safe wastewater disposal—download EPA's factsheet at www.epa.gov/region9/water/groundwater/uic-pdfs/rv-wastewater.pdf or call The National Small Flows Clearinghouse's Septic System Care hotline toll-free at 1-800-624-8301.

Take care at the drain

Your septic system contains a collection of living organisms that digest and treat household waste. Pouring toxins down your drain can kill these organisms and harm your septic system. Whether you're at the kitchen sink, bathtub, or utility sink:

- Avoid chemical drain openers for a clogged drain. Instead, use boiling water or a drain snake.
- Never pour cooking oil or grease down the drain!
- Never pour oil-based paints, solvents, or large volumes of toxic cleaners down the drain. Even latex paint waste should be minimized.
- Eliminate or limit the use of a garbage disposal, which will significantly reduce the amount of fats, grease, and solids that enter your septic tank and ultimately clog its drainfield.

Maintain your drainfield

Your drainfield—a component of your septic system that removes contaminants from the liquid that emerges from your septic tank—is an important part of your septic system. Here are a few things you should do to maintain it:

- Never park or drive on your drainfield.
- Plant trees the appropriate distance from your drainfield to keep roots from growing into your septic system. A septic service professional can advise you of the proper distance, depending on your septic tank and landscape.
- Keep roof drains, sump pumps, and other rainwater drainage systems away from your drainfield area, as excess water slows down or stops the wastewater treatment process.

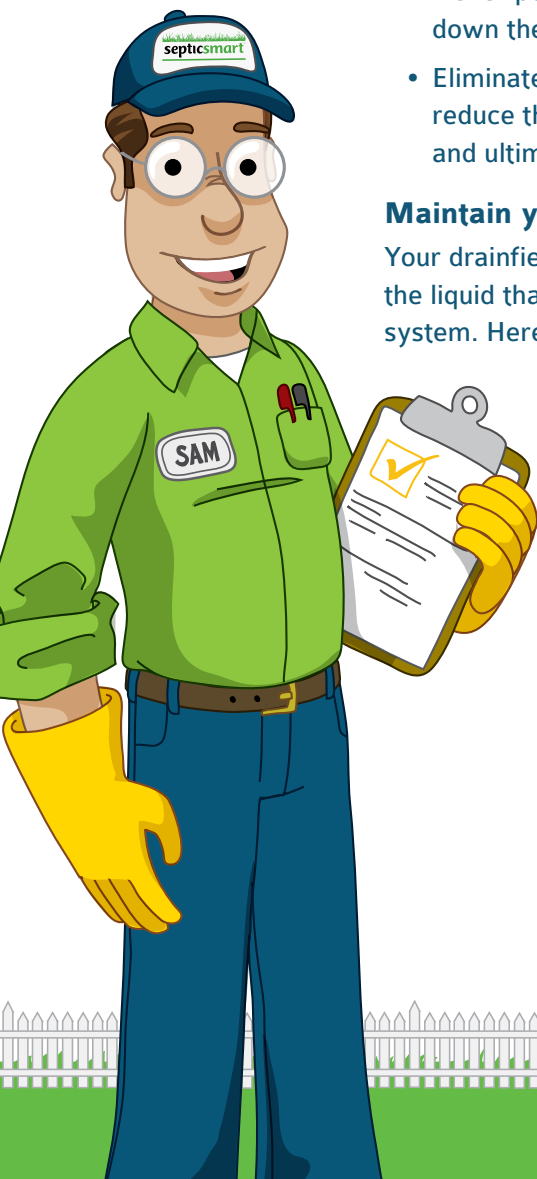

Failure Causes

Pouring household and home improvement chemicals down your drains, flushing garbage down toilets, excessive water use, and failure to provide proper maintenance aren't the only culprits for septic system failure. Take note of these additional causes of septic failure:

Hot tubs

Hot tubs may be a great way to relax, but when it comes to emptying them, your septic system should be avoided. Emptying a hot tub into your septic system stirs the solids in the tank, pushing them into the drainfield, causing it to clog and fail.

Drain cooled hot tub water onto turf or landscaped areas far away from your septic tank and drainfield, and in accordance with local regulations. Use the same caution when draining swimming pools.

Water purification and softening systems

Some freshwater purification systems, including water softeners, unnecessarily pump water into septic systems. Such systems can send hundreds of gallons of water to septic tanks, causing agitation of solids and excess flow to drainfields. When researching water purification and softening systems, check with a licensed plumbing professional about alternative routing for such treatment systems.

Garbage disposals

Consider eliminating or limit the use of garbage disposals. While convenient, frequent use of garbage disposals significantly increases the accumulation of sludge and scum in septic tanks, resulting in the need for more frequent pumping.

Improper design or installation

The proper design and installation of a septic system is essential for it to correctly function. A home's groundwater table, soil composition, and a properly leveled drainfield are just a few factors to ensure a well-functioning septic system. Be sure to do your research when hiring septic professionals.



Failure symptoms: Mind the signs!

A foul odor isn't always the first sign of a malfunctioning septic system. Call a septic professional if you notice any of the following:

- Wastewater backing up into household drains.
- Bright green, spongy grass on the drainfield, even during dry weather.
- Pooling water or muddy soil around your septic system or in your basement.
- A strong odor around the septic tank and drainfield.

Mind the signs of a failing system. One call to a septic professional could save you thousands of dollars!



U.S. Environmental Protection Agency

For more information on how you can
be SepticSmart, please visit:

www.epa.gov/septicmart

EPA-832-B-12-005
September 2012